



銳格精機股份有限公司

立式雙軸型齒輪減速機—GFD系列

Vertical-Double shaft type-
GFD series

◀ Type: GFD ▶



1/8HP
(0.1KW)

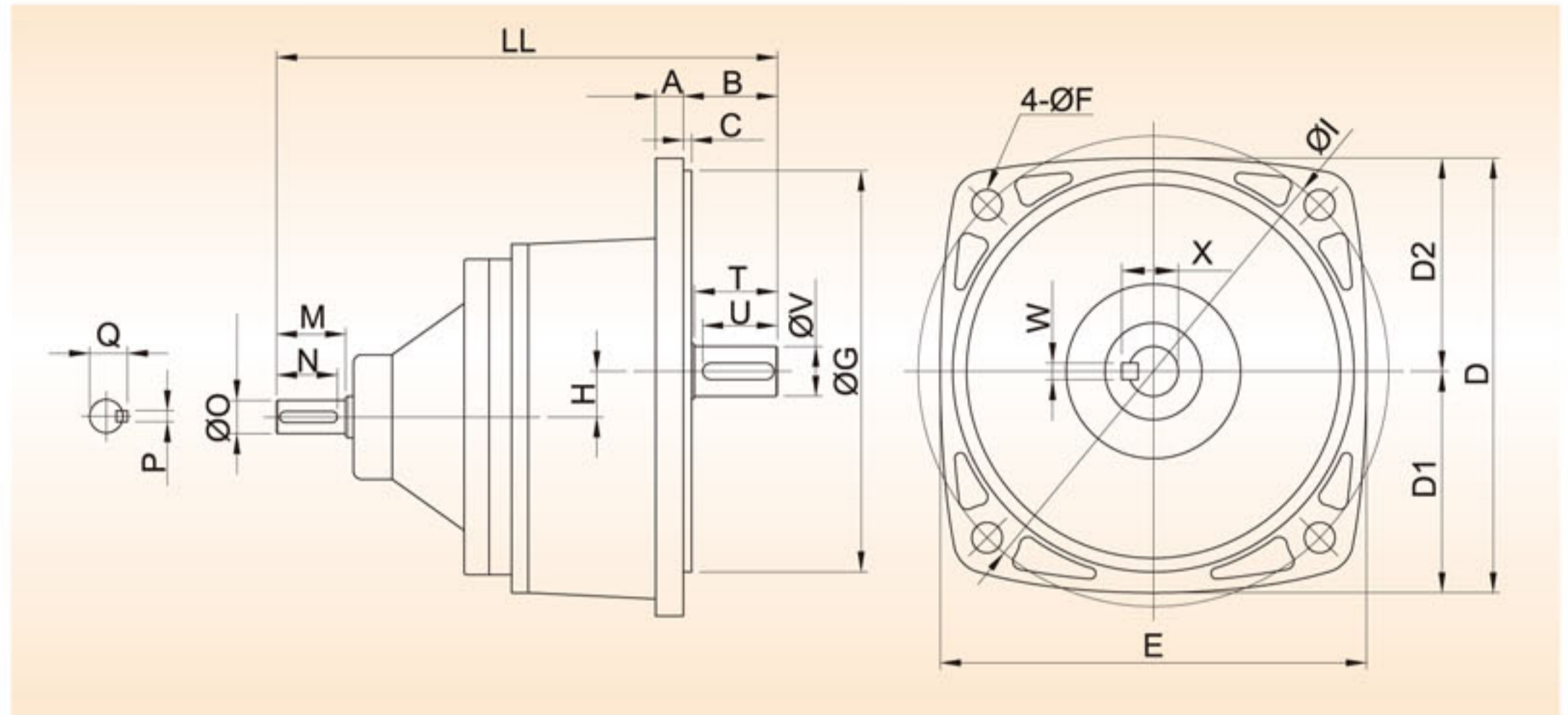

● 尺寸表 Dimensions ●

型號 SIZE	LL	A	B	C	D1	D2	D	E	ØF	ØG	H	ØI
GL-18D	181	10	34	3	80	77	157	154	11	145	16.5	170
GL-22D	208.5	12	45.5	4	89	82.5	171.5	164	11	148	19	185
GL-18D	181	10	34	3	80	77	157	154	11	145	16.5	170
GL-22D	208.5	12	45.5	4	89	82.5	171.5	164	11	148	19	185
GL-28D	227.5	15	50	4	105.5	93	198.5	186	11	170	23.5	215
GL-22D	216	12	45.5	4	89	82.5	171.5	164	11	148	19	185
GL-28D	235	15	50	4	105.5	93	198.5	186	11	170	23.5	215
GL-32D	253.5	15	61	4	126.5	107.5	234	215	13	180	28.5	250
GF-28D	245	15	50	4	105.5	93	198.5	186	11	170	23.5	215
GF-32D	262	15	61	4	126.5	107.5	234	215	13	180	28.5	250
GF-40D	310.5	18	72	5	149	135	284	270	18	230	34	310
GF-32D	289	15	61	4	126.5	107.5	234	215	13	180	28.5	250
GF-40D	333	18	72	5	149	135	284	270	18	230	34	310
GF-50D	373	25	83	5	173.5	150	323.5	300	22	270	40	360
GF-40D	339	18	72	5	149	135	284	270	18	230	34	310
GF-50D	379	25	83	5	173.5	150	323.5	300	22	270	40	360
GL-50D	384	25	83	5	173.5	150	323.5	300	22	270	40	360

型號 SIZE	比數 RATIO	馬力 HP	入力軸 INPUT SHAFT					出力軸 OUTPUT SHAFT				
			M	N	ØO	P	Q	T	U	ØV	W	X
GF-18D	5~50	1/8	25	22	12	4	13.7	28	27	18	6	20.5
GF-22D	60~200	0.1KW	25	22	12	4	13.7	38	35	22	6	24.6
GF-18D	5~30	1/4 0.2KW	25	22	12	4	13.7	28	27	18	6	20.5
GF-22D	30~100		25	22	12	4	13.7	38	35	22	6	24.6
GF-28D	120~200	1/2 0.4KW	25	22	12	4	13.7	43	40	28	8	31.4
GF-22D	5~25		30	27	15	5	17.1	38	35	22	6	24.6
GF-28D	30~100	1 0.75KW	30	27	15	5	17.1	43	40	28	8	31.4
GF-32D	120~200		30	27	15	5	17.1	53	50	32	10	35.2
GF-28D	5~25	2 1.5KW	35	32	20	6	22.5	43	40	28	8	31.4
GF-32D	30~100		35	32	20	6	22.5	53	50	32	10	35.2
GF-40D	120~200	3 2.2KW	35	32	20	6	22.5	63	58	40	12	43
GF-32D	5~25		40	35	25	8	27.8	53	50	32	10	35.2
GF-40D	30~100	5 3.7KW	40	35	25	8	27.8	63	58	40	12	43
GF-50D	120~200		40	35	25	8	27.8	75	70	50	14	53.5
GF-40D	5~25	5 3.7KW	45	40	30	8	33	63	58	40	12	43
GF-50D	30~100		45	40	30	8	33	75	70	50	14	53.5
GF-50D	5~25		50	45	32	10	38.3	75	70	50	14	53.5